

Lead Safe Prison Wall Top Assy - Extended

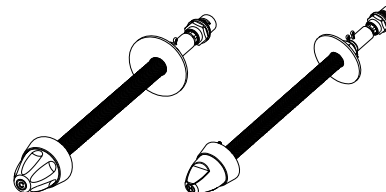

PRODUCT CODES	DESCRIPTION
121.42.03.01	SAFE-CELL CP-BS LEAD SAFE PRISON EZY- GRIP WALL TOP ASS - EXTENDED 300 COMP COLD C/D
121.43.03.01	SAFE-CELL CP-BS LEAD SAFE PRISON MULTI- GRIP WALL TOP ASS - EXTENDED 300 COMP COLD C/D
121.42.03.02	GALVINCARE CP-BS LEAD SAFE PRISON EZY- GRIP WALL TOP ASS - EXTENDED 300 COMP HOT C/D
121.43.03.02	GALVINCARE CP-BS LEAD SAFE PRISON MULTI- GRIP WALL TOP ASS - EXTENDED 300 COMP HOT C/D

SPECIFICATIONS

- Designed for maximum protection against vandalism, Safe-Cell® Wall Top Assemblies with extended nipples are made from heavy duty components and are designed to be installed from behind the wall.
- The wall assembly is made of chrome plated brass.
- Quarter turn ceramic disc.
- Machined cold or hot identification button.
- Designed to suit wall thickness up to 240mm.
- Anti-ligature design for added safety.
- Available with either Ezy-Grip or Multi-Grip handle (as shown above).

IMPORTANT: All Wall Top assemblies are tested in accordance with AS/NZS 3718 and leave our premises in good working order.

*As 'lead free' is not currently defined by law in Australia and New Zealand, we have based our definition of Lead Safe™ on the requirements of Sec. 1417 of the USA's Safe Drinking Water Act (SDWA) and the relevant US standards NSF61 / NSF372. The SDWA defines 'lead free' as "not more than a weighted average of 0.25% lead when used with respect to the wetted surface of pipes, pipe fittings, plumbing fittings and fixtures".

WARNINGS: Special attention to be paid on notes, photos, images, or drawings of assembly steps marked with the warning symbol.



TECHNICAL DATA

Inlet	5/8" BSP - Male	
Outlet	N/A	
Headwork	Ceramic Disc	
Working Pressure Range (kPa)	Min	50
	Max	500
Working Temperature Range (°C)	Min	5
	Max	65
Nominal Flow Rate (LPM)	N/A	
Finish	Chrome	

NOTE: Galvin Engineering continually strive to improve their products. Specifications may change without notice.

TOOLS REQUIRED

- Power drill
- Spanner or adjustable crescent

PRE-INSTALLATION

MOUNTING DETAILS – HOLE CENTRES

- If the mounting holes do not already exist, mark out and drill the holes in the wall, as shown in rough-in dimensions.
- Ensure the valve body is mounted inline with the $\varnothing 21$ hole.

⚠ Note: Before installation, all lines must be flushed. We recommend that a line strainer be installed prior to Drinking Taps to eliminate any foreign material.

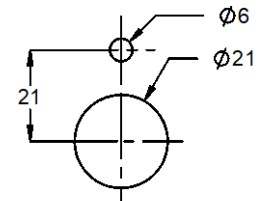

⚠ ROUGH IN DIMENSIONS

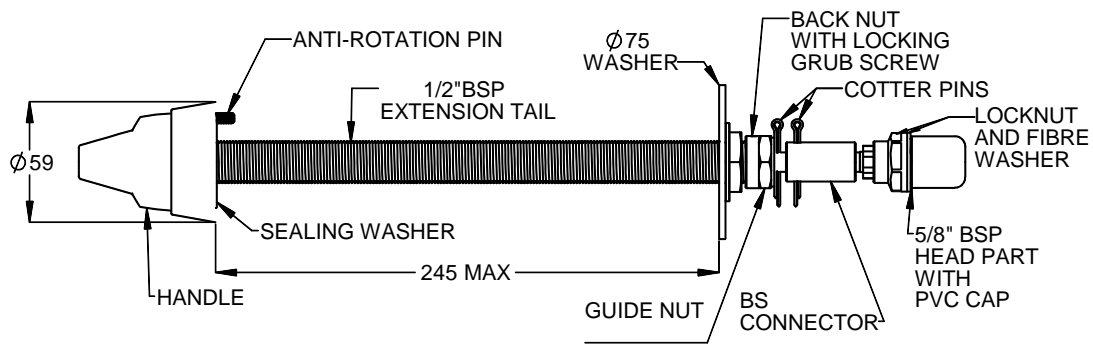

EZY-GRIP ASSEMBLY

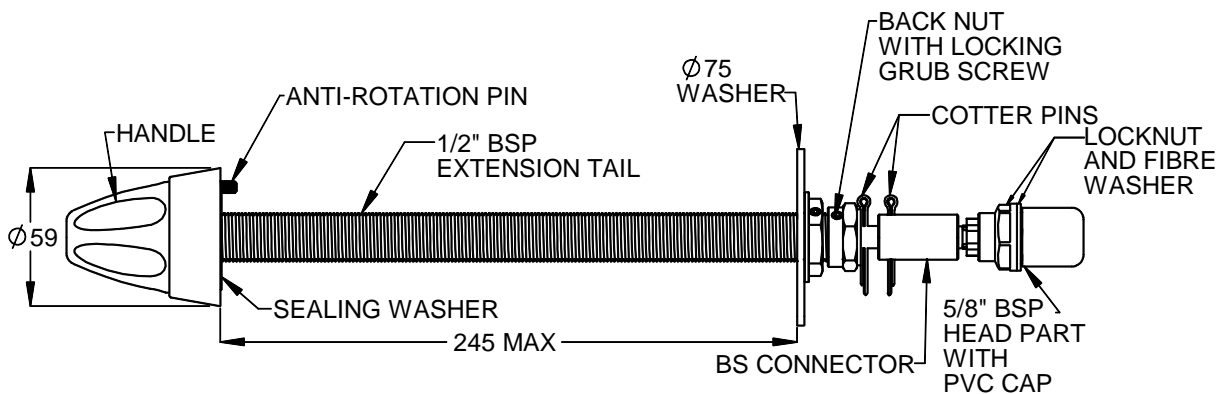

MULTI-GRIP ASSEMBLY

INSTALLATION

INSTALLATION COMPLIANCE: Galvin Engineering products must be installed in accordance with these installation instructions and in accordance with AS/NZS 3500, the PCA and your local regulatory requirements. Water and/or electrical supply conditions must also comply to the applicable national and/or state standards. Failing to comply with these provisions shall void the product warranty and may affect the performance of the product.

IMPORTANT: Whilst our product designs take into account a broad range of installation types and surfaces, it is important that surfaces which fixtures are mounted to are flat and free from defect. This is especially important when installing product ranges that have been designed for correctional and health facilities, where special attention is required to minimise ligature points and areas for concealment of contraband. In addition to ensuring the products are fitted securely and in accordance with the following instructions, consideration shall be given to the use of non-pick mastics such as BASF Sonolastic “Ultra” to ensure a high quality and safe installation.

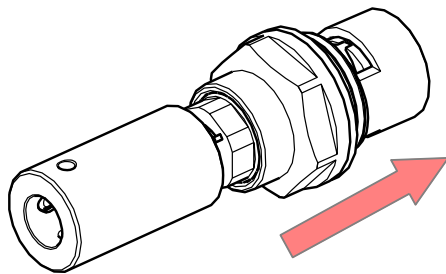

1. Fit head part

- Remove PVC cap and fit head part to valve body, do not overtighten

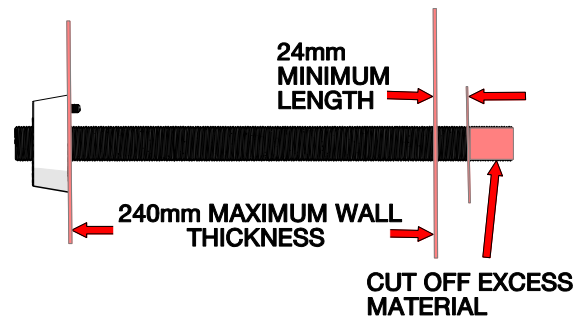

2. Check dress flange length

- Insert dress flange through the wall and mark for cutting if too long. Ensure a minimum of 24mm protruding from the wall and cut where marked. Remove any burrs.

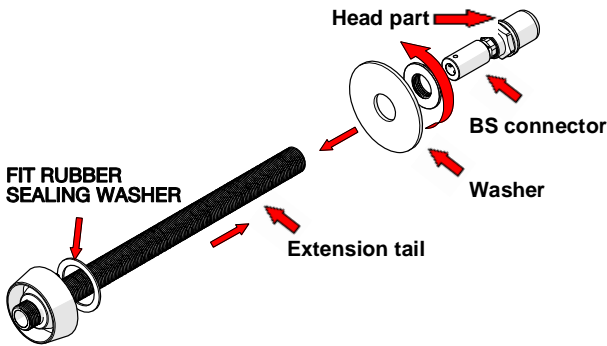

3. Fit dress flange

- Fit rubber sealing washer to the dress flange and re-insert. Secure using the large galvanised washer and flanged backnut.

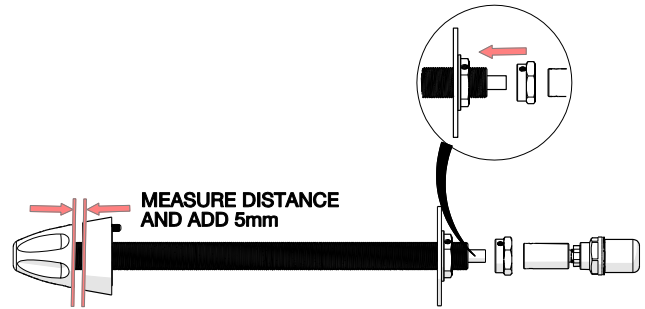

4. Shorten handle shaft

- Fit the guide nut to the end and tighten lightly
- Insert the handle through the dress flange and into the stainless-steel connector which is fitted to the headpart.
- Measure the distance from the underside of the handle to the top of the dress flange and add 5mm. This is the amount that the handle needs to be shortened by.
- Remove the handle and mark this distance from the end of the shaft and cut, remove any burrs.

⚠ Note: If the skirt of the handle enters the dress flange by more than 3mm then the handle does not need to be shortened.

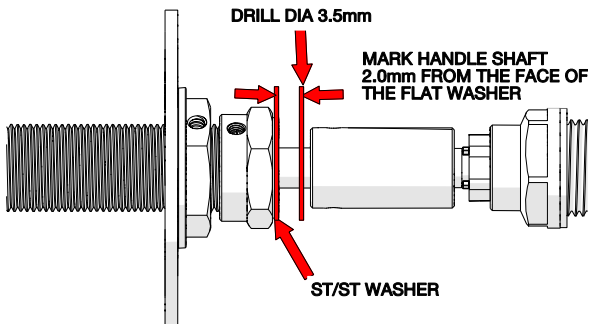

5. Fit handle

- Fit the handle through the dress flange, guide nut and stainless-steel washer before entering the stainless-steel connector on the head part.
- Ensure the handle is sitting securely in the dress flange. When pushed against the dress flange, the handle should turn freely without rubbing on the dress flange.
- Hold the stainless steel washer against the guide nut and mark the shaft 2mm from the face of the washer. Remove the handle and drill a $\varnothing 3.5\text{mm}$ hole through the shaft where marked.

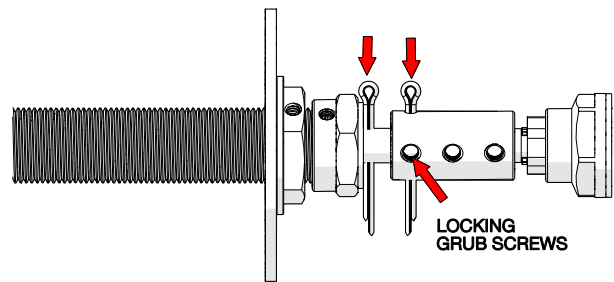

6. Connect handle

- Fit the handle as per step 5
- Ensure the headpart is in the closed position and the handle is orientated to your requirements.
- Tighten the locking grub screw and re-check handle position. Then, using the drilled hole in the stainless-steel connector as a guide, drill through the extended handle shaft with a $\varnothing 3.5\text{mm}$ drill.
- Fit the cotter pins through the 2 drilled holes and bend over the ends to stop the cotter pins falling out during use.

⚠ If necessary, adjust the guide nut to reduce any gap between the stainless-steel washer and cotter pin. This reduces end play movement in the handle. After adjustment, ensure the handle turns freely

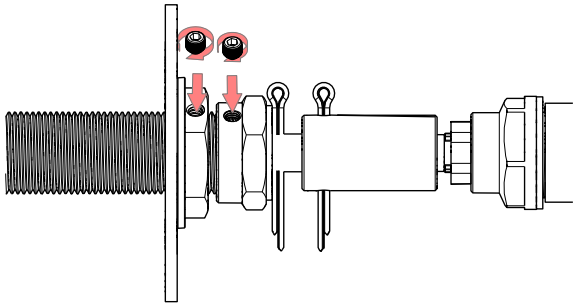
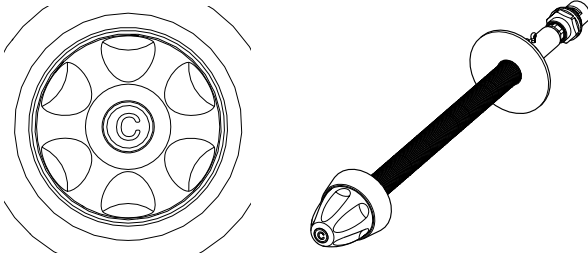
 <p>7. Fit the grub screws</p> <ul style="list-style-type: none"> Fit the supplied grub screws into the guide nut and the flanged back nut and lock securely. 	 <p>8. Checking & testing</p> <ul style="list-style-type: none"> Check to ensure the wall top assembly functions. Connect water supply, inspect the tap and check for any leaks.
----------------------------------------------------------------------------------------------------------------------------------------------------------------------------------------------------------------------------------------------------------------------	-------------------------------------------------------------------------------------------------------------------------------------------------------------------------------------------------------------------------------------------------------------------------------------------------------

TROUBLESHOOTING		
PROBLEM	CAUSE	RECTIFICATION
Taps are dripping water	Ceramic cartridge is worn or damaged	Remove and inspect the cartridge, remove debris and /or replace cartridge if damaged
Water is not flowing from tap	Water is turned off	Turn on water

WARRANTY

The warranty set forth herein is given expressly and is the only warranty given by the Galvin Engineering Pty Ltd. With respect to the product, Galvin Engineering Pty Ltd makes no other warranties, express or implied. Galvin Engineering Pty. Ltd. hereby specifically disclaims all other warranties, express or implied, including but not limited to the implied warranties of merchantability and fitness for a particular purpose.

Galvin Engineering Pty Ltd products are covered under our manufacturer’s warranty available for download from www.galvinengineering.com.au Galvin Engineering Pty Ltd expressly warrants that the product is free from operational defects in workmanship and materials for the warranty period as shown on the schedule in the manufacturer’s warranty. During the warranty period, Galvin Engineering will replace or repair any defective products manufactured by Galvin Engineering without charge, so long as the terms of the Manufacturer’s warranty are complied with.

The remedy described in the first paragraph of this warranty shall constitute the sole and exclusive remedy for breach of warranty, and Galvin Engineering Pty Ltd shall not be responsible for any incidental, special or consequential damages, including without limitation, lost profits or the cost of repairing or replacing other property which is damaged if this product does not work properly, other costs resulting from labour charges, delays, vandalism, negligence, fouling caused by foreign material, damage from adverse water conditions, chemical, electrical or any other circumstances over which Galvin Engineering has no control. This warranty shall be invalidated by any abuse, misuse, misapplication, improper installation or improper maintenance or alteration of the product.